

ITEM	QTY.	PART NUMBER	DESCRIPTION
1	1	1006379	SHELL WELDMENT
2	1	(SEE CHART)	UNIT HUB
3	1	1050375	ASY BLK&BRDG 200A 7T
4	1	1005189	NEUTRAL BUS ASSY
5	1	1000183	SCREW 12-24 x 5/16
6	1	1008132	SCW 12-24X.500 SLT HX TF
7	1	1094928	FRONT ASSEMBLY
8	1	1000158	PAD WIREMAN, 8.37 x 7.50
9	1	1134973	LABEL, NON-UL 200A CONT. UNIT
10	1	1000064	LABEL, DANGER
11	0.25	1000185	CARTON 4-PER (MULTI PACK) (NOT SHOWN)

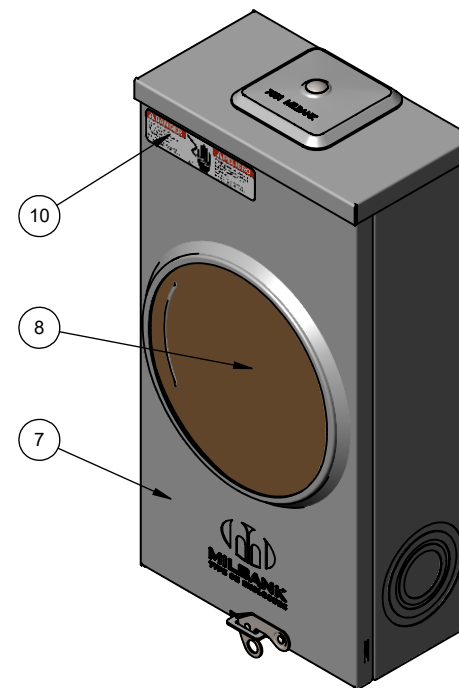

ITEM	QTY.	FEATURE
A	3	1, 1 1/4, 1 1/2, 2, 2 1/2 CONC. K.O.
B	1	1/4, 1/2 CONC. K.O.
C	2	1, 1 1/4, 1 1/2, 2 CONC. K.O.
D	1	1/4" SOLID K.O.
E	6	U/L MOUNTING EMBOSS

NOTES:
1. FOR SPANISH VERSION SEE DWG. #2417-21.

SUFFIX	SMALL HUB TYPE	HUB / SCREWS
-O	NO OPENING	NONE
-RL	HUB OPENING	NONE
-XL	CLOSING PLATE (A7551)	1028222
-WL	1" (A7514)	1028195 / 1156422 (4)
-YL	1 1/4" (A7515)	1000006 / 1156422 (4)
-ZL	1 1/2" (A7516)	1003422 / 1156422 (4)
-DL	2" (A7517)	1000007 / 1156422 (4)
-EL	2 1/2" (A7518)	1028196 / 1156422 (4)

Material:	16 GA. STL.
Shear/Die No.:	~
Finish:	MILBANK LIGHT GRAY
Part Wt.:	10.684 LBS. EA.
Square Inches:	~
Tolerances: Unless Specified Otherwise	Third Angle
X.X	±.1
X.XX	±.03
X.XXX	±.015
X"	±2"
Scale:	NTS
Checked By:	
Drawn By:	JWH
Approved By:	



Title: 200A RINGLESS 7 TERM 350 kcmil METER SOCKET

Catalog No.: S2417-(-)

Customer: MILBANK STANDARD

Drawing No.: 2417

REV.	DATE	DESCRIPTION	ECO No.	BY
A	06/24/20	UPDATED TITLE BLOCK; REM UNUSED CHARTS; 1156422 WAS 1008132; MOVED WELDMENTS TO DRAWINGS 1006379 AND 1006393	045699	SP
B	08/25/20	1008132 WAS 1156422	046237	BLY
B1	03/12/21	CORRECTED HUB CHART TO MATCH ERP	047645	BLY

Date: 6/26/12 Sheet: 1 of 1