

ITEM	QTY.	PART NUMBER	DESCRIPTION
1	1	(SEE CHART)	SHELL WELDMNT
2	1	(SEE CHART)	CLOSING PLATE ASSY.
3	1	(SEE CHART)	FRONT ASSY.
4	2	(SEE CHART)	SEALING RING
5	1	1000340	900 SERIES BRIDGE
6	1	(SEE CHART)	BLK ASSY 2/0 100 AMP RL LEFT
7	1	(SEE CHART)	BLK ASSY 2/0 100 AMP RL RIGHT
8	1	(SEE CHART)	CONNECTOR 2/0
9	2	1000389	2/0 NUT CONNECTOR
10	S/C	1000394	TRIPLEX/QUADPLEX GND. ASSY
11	S/C	1152185	INSULATOR
12	4	1000165	SCREW 10-32 x 1.125 T/F
13	1	1047088	SCW, 10-32 X 3/4 SHW
14	S/C	1156169	LABEL, CLEARANCE; BGE
15	1	(SEE CHART)	LABEL, UL METER SOCKET
16	1	(SEE CHART)	LABEL, RATING
17	1	1000061	WIREMAN PAD (RND)
18	1	(SEE CHART)	CARTON (NOT SHOWN)

CATALOG NO.	U/L LABEL	RATING LABEL	SHELL	CARTON	QTY. PER CARTON
U7490-O(-)	1000166	1224705	#1005057	#1000186	4-PER
S7490-O(-)	-	1134974			
R7490(-)				#1005228	1-PER
U7490(-)	1000166	1224705	#1000297		
S7490(-)	-	1134974		#1000186	4-PER
UAP7490(-)	1000166	1224705	#1115332		

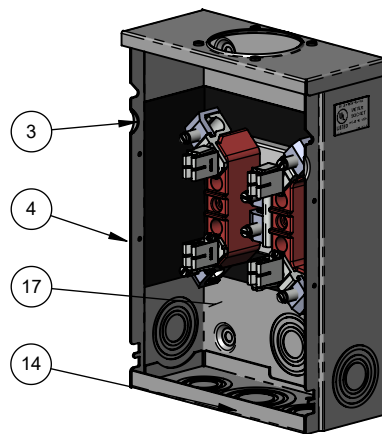
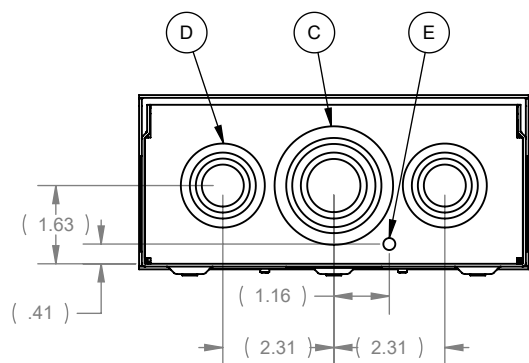

SEE PAGE 2 FOR NOTES & CHARTS

ITEM	QTY.	DESCRIPTION
A	3	.75, 1, 1.25, 1.50 CONC. K.O.
B	6	U/L MOUNTING EMBOSS
C	1	.75, 1, 1.25, 1.50 CONC. K.O.
D	2	.50, .75, 1, 1.25 CONC. K.O.
E	1	.25 SOLID K.O.

REV.	DATE	DESCRIPTION	ECO No.	BY
X5	01/17/19	1047088 (QTY. 1) WAS 1000062 (QTY. 1); ADD WELDMNT SHEET; UPDATE DRAWING TO STANDARD	040840	BU
X6	05/09/19	MOVED SHELL WELDMNT TO DRAWING 100297	041881	SP
Y	10/14/21	1224705 WAS 1000051; CHARTED 1134974	048847	DL

Material: 16 GA. STEEL OR .064 ALUM		 <p>MILBANK ENERGY AT WORK KANSAS CITY, MO USA</p>
Shear/Die No.:		
Finish:	MILBANK LIGHT GRAY	Title: M/S 125 AMP RINGTYPE 4 OR 5 TERM 2/0
Part Wt.:	9 LBS. EA.	
Square Inches:		Catalog No.: ()7490(-)
Tolerances: Unless Specified Otherwise X.X ±.1 X.XX ±.03 X.XXX ±.015 X" ±2"	Third Angle	
Scale:	NTS	Customer: MILBANK STANDARD
Checked By:		Drawing No.: 7490
Approved By:		
Drawn By:	DL	Date: 8-14-09
Approved By:		Sheet: 1 of 2

SUFFIX	FRONT ASSY.
NONE	#1098886 (SC) #1115381 (AC)
-NGE	#1106626 (SC)
-CE	#1100642 (SC)

SUFFIX	PART#
NONE (MR-2)	1000109 (AO)
-M4 (MR-4)	1000110 (SS)
-M4SS (MR-4SS)	1000110 (SS)
-M8 (MR-8)	1028731 (SS)

SUFFIX	1152185 QTY.
NONE	0
-INS	1

SUFFIX	SMALL HUB TYPE	HUB / SCREWS
-O	NO OPENING	NONE
-RL	HUB OPENING	NONE
-XL	CLOSING PLATE (A7551)	1028222
-WL	1" (A7514)	1028195 / 1156422 (4)
-YL	1 1/4" (A7515)	1000006 / 1156422 (4)
-ZL	1 1/2" (A7516)	1003422 / 1156422 (4)
-DL	2" (A7517)	1000007 / 1156422 (4)
-EL	2 1/2" (A7518)	1028196 / 1156422 (4)

SUFFIX	1156169 QTY
NONE	N/A
-BGE	1

SUFFIX	L. BLOCK ASSY.	R. BLOCK ASSY.	GROUND CONNECTOR	TRIPLEX GROUND CONNECTOR QTY.
NONE	#1031738	#1031738	#1000083	0
-TG	#1031738	#1031738	#1000083	1
-5T	#1004964	#1031738	#1000083	0
-6T	#1004964	#1004964	#1000083	0
-TG-6T	#1004964	#1004964	#1000083	1

SALES NOTES:

- FOR FIELD INSTALLED FIFTH TERM. ASSY. ORDER CAT. #5T8K2.
- FOR FIELD INSTALLATION OF ISOLATED NEUTRAL CONNECTOR ASSEMBLY ORDER KIT #K5709.
- SUFFIX -AEP, MEANS FOR UTILITY USE ONLY.

PRODUCTION NOTES:

- WHEN SOLD AS -CE CARTON LABEL REQUIRES CONSUMERS ENERGY STOCK NUMBER IN THE CATALOG NUMBER POSITION AND CATALOG NUMBER IN THE SECOND DESCRIPTION POSITION. ENTER CUSTOMER BILLING #062500 IN THE FREIGHT LINE/NOTE FIELD. CONSUMERS ENERGY STOCK NO. 14-85440.
- WHEN SOLD W/ "R" PREFIX, UNIT TO BE SINGLE PACKED IN CARTON #1005228 WITH CARTON LABEL BELOW:
 R7490-RL: #1131035
 R7490-RL-TG: #1130567
 R7490-RL-TG-M4: #1133532
 R7490-XL: #1131036
 R7490-XL-TG: #1132289
- BG&E ORDERS TO BE SHIPPED ON 48x40 PALLET #1092264. STACK PRODUCT FLAT, NOT ON EDGE. WEIGHT NOT TO EXCEED 2,000 LBS. "B.G.&E. 13068" TO BE ON THE CARTON LABEL.

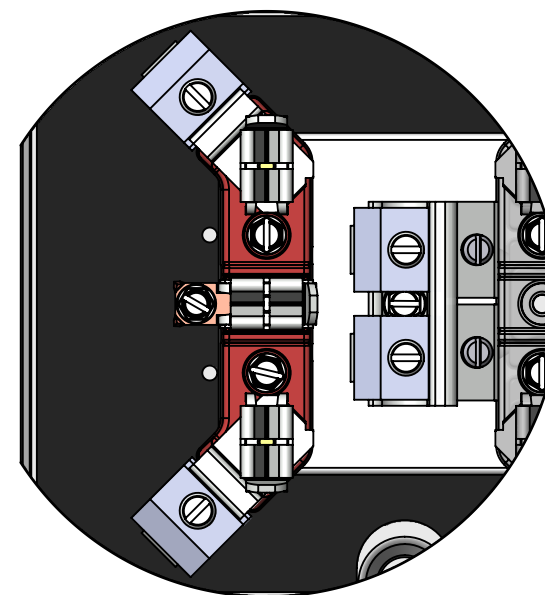

-5T CONFIGURATION

DETAIL B
SCALE 1 : 2

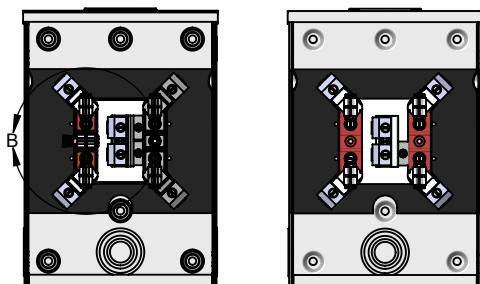

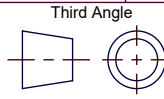
Material:	16 GA. STEEL OR .064 ALUM		 <p>KANSAS CITY, MO USA</p>
Shear/Die No.:			
Finish:	MILBANK LIGHT GRAY		Title: M/S 125 AMP RINGTYPE 4 OR 5 TERM 2/0 Catalog No.: ()7490-() Customer: MILBANK STANDARD
Part Wt.:	9	LBS. EA.	
Square Inches:			Drawing No.: 7490 Date: 8-14-09 Sheet: 2 of 2
Tolerances: Unless Specified Otherwise	Third Angle 		
X.X	±.1		Drawn By: DL Checked By: Approved By:
X.XX	±.03		
X.XXX	±.015		Scale: NTS
X"	±2"		

REV.	DATE	DESCRIPTION	ECO No.	BY
X5	01/17/19	1047088 (QTY. 1) WAS 1000062 (QTY. 1); ADD WELDMENT SHEET; UPDATE DRAWING TO STANDARD	040840	BU
X6	05/09/19	MOVED SHELL WELDMENT TO DRAWING 100297	041881	SP
Y	10/14/21	1224705 WAS 1000051; CHARTED 1134974	048847	DL